

Section I – Installation Preparation

Part Number: PT904-52082

Kit Contents

Item #	Quantity Req'd.	Description
1	1	Alloy Wheel Painted

Hardware Bag Contents

Item #	Quantity Req'd.	Description
1	1	Center Cap Painted PT904-52040-CC
2	5	Lugnuts (90084-94001)

Additional Items Required For Installation

Item #	Quantity Req'd.	Description
1	As Required	Balance Weight, Clip-on Type (Hofmann Standard) 90942-03146 thru 03160, 03167 90942-03208 thru 03214
2	As Required	Balance Weight, Stick-on Type (Hofmann Standard) 00533-10010
3	1	B-pillar Tire Pressure Label MDC P/N 00107-00701
4	1	Owners Manual Label MDC P/N 00107-00702
5	1	Snow Chain Label, Owner's Manual MDC P/N 00602-35065

Conflicts

Note: Wheel Cover

General Applicability

Applicable to Scion xB 2008 -
Use with tire size 225/45R17

Recommended Sequence of Application

Item #	Accessory	
1	Alloy Wheel	
2	Wheel Lock	

*Mandatory

Recommended Tools

Safety Tools	
Safety Glasses	
Seat Protection	Blankets
Special Tools	
Wheel Balancing Machine	Hunter GSP9700 (preferred), DSP9500 or equivalent
Tire Mounting Machine	Hunter TC3250 or equivalent
Centering Cone	Hunter 192-51-2
Foot Brake Application Tool	IADS P/N – AN99-025-01
Surface Thermometer	Infrared Non-contact
Installation Tools	
Valve Stem Insertion Tool	
Lugnut Wrench	
Rubber Mallet	
Torque Wrench (lug nuts)	0-250 lbf•ft (340 N•m)
Torque Wrench (TPMS sensor)	0- 30 N•m
Ratcheting Wrench	
Sockets	12mm & 21 mm Deep Well
Balance Weight Pliers	
Clean Lint-free Cloth	
Nylon Panel Removal Tool	e.g. Panel Pry Tool #1 Toyota SST # 00002-06001-01

Special Chemicals	
Tire Lube	Myers Tire Supply
Cleaner (for re-work only)	Mild soap & water or approved cleaner

Legend

 **STOP:** Damage to the vehicle may occur. Do not proceed until process has been complied with.

 **OPERATOR SAFETY:** Use caution to avoid risk of injury.

 **CAUTION:** A process that must be carefully observed in order to reduce the risk of damage to the accessory/vehicle and to ensure a quality installation.

 **TOOLS & EQUIPMENT:** Used in Figures calls out the specific tools and equipment recommended for this process.

 **REVISION MARK:** This mark highlights a change in installation with respect to previous issue.

 **SAFETY TORQUE:** This mark indicates that torque is related to safety.

A. Vehicle Preparation



1. Firmly apply parking brake. (Fig. A-1)



2. Put transmission in “P” (automatic) or reverse (manual). (Fig. A-2)

3. Add seat protection (blanket) and apply foot brake using foot brake application tool. (Fig. A-3)

4. Lift vehicle.



5. Remove OE wheel and tire assemblies from vehicle. Wear safety glasses while removing wheels. (Fig. A-4)

6. Dismount OE tire from the wheel.

- i. Remove the valve core and release pressure from the tire.
- ii. Remove the nut and washer and let the pressure sensor drop inside the tire.
- ii. Carefully separate the upper tire bead from the wheel rim. (Fig. A-5)

Note: Be careful not to damage the tire pressure monitor due to interference between the sensor and tire bead

7. Remove the sensor from the tire and remove the bead on the lower side as in usual tire removal operation.

8. Dismount OE tire from the OE wheel.

B. Install Tire Pressure Monitor Valve Sub-assembly to Accessory Wheel.

- 1. Visually check that there is no deformation or damage on the tire pressure monitor valve sub-assembly.
- 2. Check that the rim is clean.



Fig. A-1



Fig. A-2

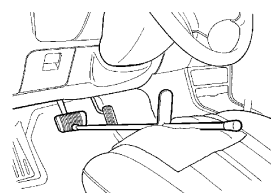

Fig. A-3



Fig. A-4

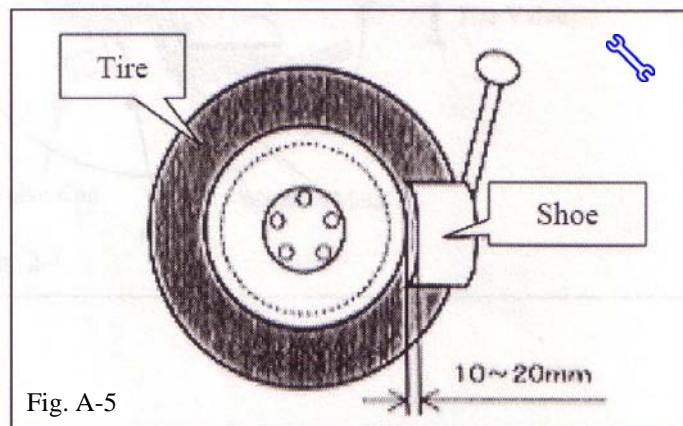

Fig. A-5

3. Change the original grommet to a new one if the grommet is damaged.

STOP NOTE: Damaged grommet is NOT re-usable.

4. Check that the grommet, washer and nut are clean.
5. Insert the tire pressure monitor valve sub-assembly into the valve installation hole from the inside of the rim and bring the valve stem to the outside. (Fig. B-1).
 - i. Insert the tire pressure monitor valve sub-assembly so that manufacturer’s mark is visible.

STOP NOTE: Incorrect orientation of pressure monitor sub-assembly may cause damage and prevent signal transmission during high-speed running.

6. Install the washer and secure with the nut.

S  i. Tighten the nut to 4.0 N-m (36 lbf-in)

C. Tire Mounting

-  1. Use tire lube around bead location on wheel prior to mounting the tire. Mount new tire (225/45R17) on alloy wheel, matching tire high spot (red dot) with that of wheel low spot (green sticker). The red dot on tire and green dot on wheel must be aligned to within ± 15 mm center to center. (Fig. C-1)

NOTE: If the green sticker on the wheel is missing, then align the red dot on the tire to the valve stem location on the wheel.

2. Position the wheel on the mounting machine with the sensor at ~ 7 o'clock position (shaded area in Fig. C-2)
 - i. Mount/dismount head is considered as 12 o'clock Position.

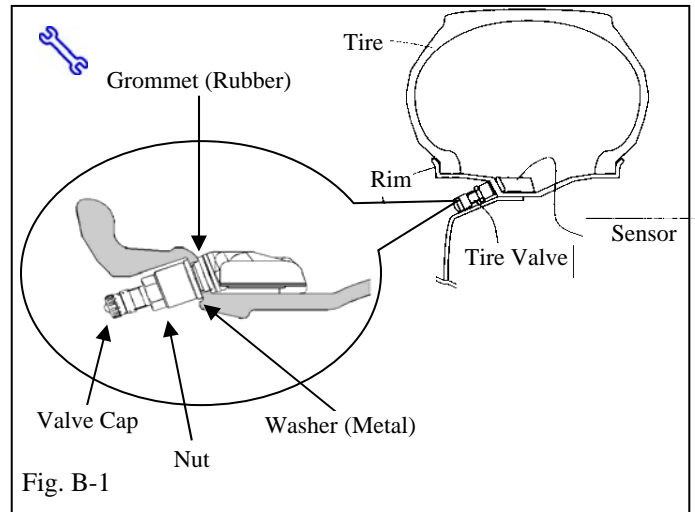

Fig. B-1

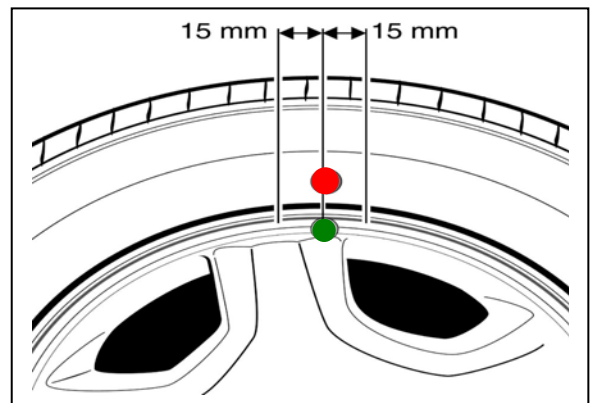

Fig. C-1

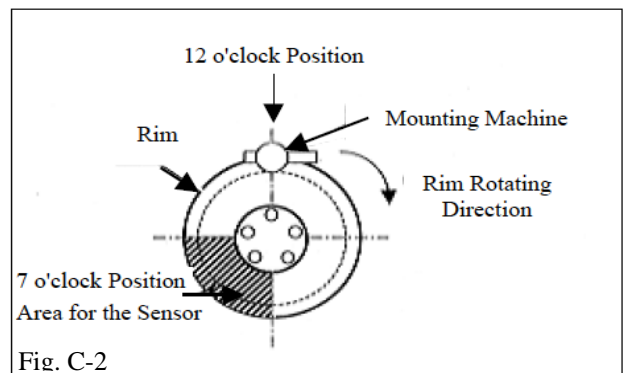

Fig. C-2

3. Mount the lower tire bead.

STOP **NOTE:** If the sensor is positioned outside this area, it generates interference with the tire bead, causing possible damage to the sensor.

4. Re-position the wheel on the mounting machine with the sensor at ~ 5 o'clock position (shaded area in Fig. C-3)

5. Mount upper tire bead.

STOP **NOTE:** Make sure that the tire bead and tool does not interfere with the main body of the sensor and the bead does not clamp the sensor.

➡ 6. To seat tire bead, inflate tire beyond 32 PSI but not more than the maximum tire bead seat pressure indicated on the tire sidewall, if not indicated, use 40 PSI as a limit. If tire bead is not seated when pressure registers 40 PSI, deflate the tire and re-inflate to seat the bead. Regulate the tire pressure per the value listed on the new B-pillar sticker MDC P/N 00107-00701.



7. After the tire is inflated, the valve nut may be loose. Retighten the nut to the specified torque and then check for air leaks with soapy water.



i. Tighten the nut to 4.0 N-m (36 lbf-in)

D. Wheel Balancing

NOTES: Application temperature for stick-on type weight: above 10°C (50°F). It is good practice to apply the stick-on type weights in sections comprising no more than 5 or 6 individual weight segments. This wheel requires stick-on weight on outer and clip-on weight on inner rim for correct balancing.

➡ 1. Mount wheel/tire on wheel balance machine and balance in DYNAMIC MODE. Enable the LOAD ROLLER, if applicable (enabling the load roller ensures proper bead seating.)

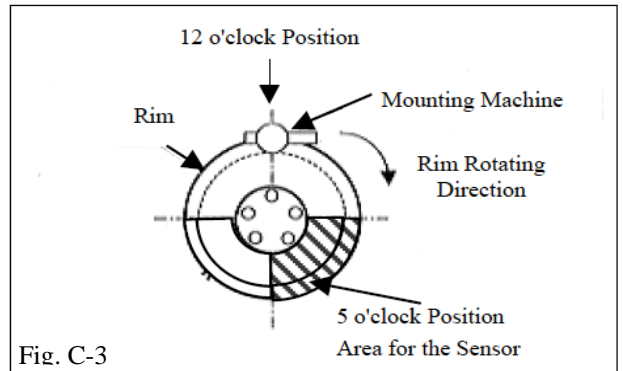

Fig. C-3

Use clip-on type balance weight on the inner rim lip and stick-on type weights at outer location. (Fig. D-1 & Fig. D-2)

- ➔ 2. Prior to mounting stick-on type wipe down the wheel weight mounting location on wheel with a clean lint-free dry cloth. Ensure that location is clean and dry. Apply stick-on weights at perimeter location identified by dynamic balance machine as shown. Use rubber mallet, if required, to achieve complete adhesion of stick-on type weight.

NOTES: Maximum clip-on type weight on inner lip is 80 g. Maximum stick-on type weight at outer location is 98 g. If removal and replacement of stick-on type weight is necessitated, then remove the weights using a nylon removal tool. Clean the surface with a mild soap or approved cleaner. Wipe the surface dry before re-applying a new weight. **(DO NOT RE-USE STICK-ON WEIGHTS.)**

- ➔ 3. Re-spin the wheel on the machine with **LOAD ROLLER DISABLED** (if applicable) and note the indicated remainder unbalance. The maximum permitted unbalance is 8 g at inner lip and 8 g at outer location.

E. Vehicle Wheel/Tire installation



- 1. Install wheel/tire assembly on vehicle. Hand start the lugnuts during installation. Tighten lugnuts in sequence 1 through 5. Ensure that the socket does not scuff the wheel. Tighten to 76 lbf•ft (103 N•m) using a torque wrench. (Fig. E-1)

- 2. Lower the vehicle.



- 3. Install valve stem cap.
- 4. **NOTE:** For PDS vehicles the pressure should be adjusted to the value listed on the new B-pillar sticker MDC P/N 00107-00701 for each vehicle prior to customer delivery.

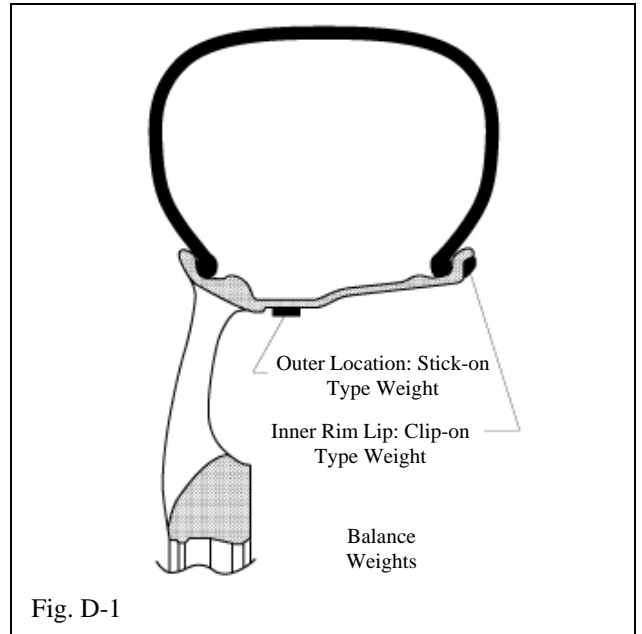

Fig. D-1

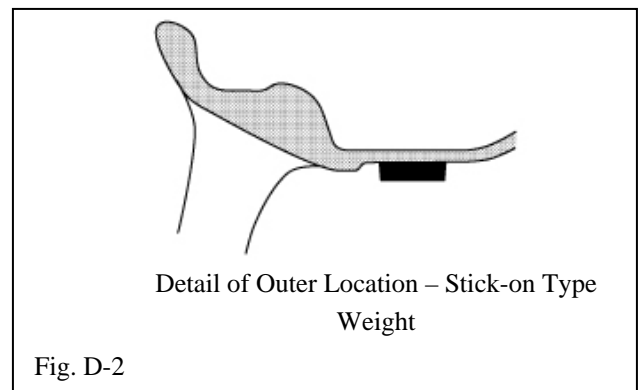

Fig. D-2

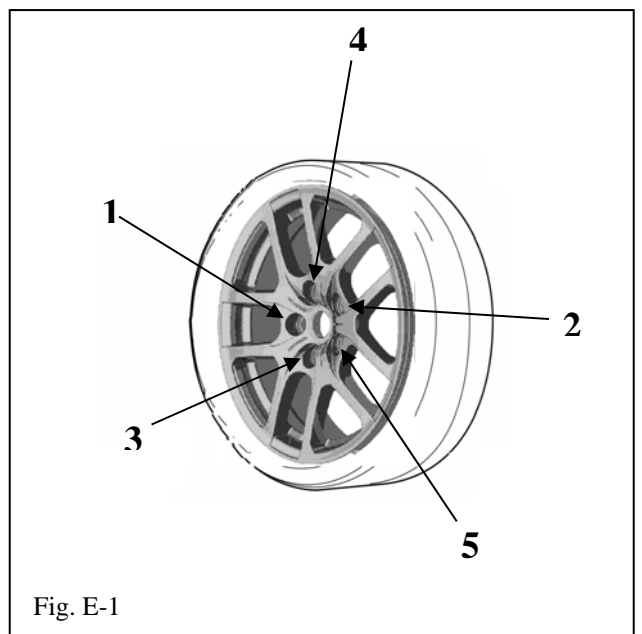

Fig. E-1

F. Center Cap Installation

1. Place four (4) center caps in the rear cargo area.

NOTE: For PDS vehicles install center caps on wheels. Align the retention claws on the cap to the center bore on the wheel and gently push cap into wheel until cap snaps into place. (Fig. F-1)

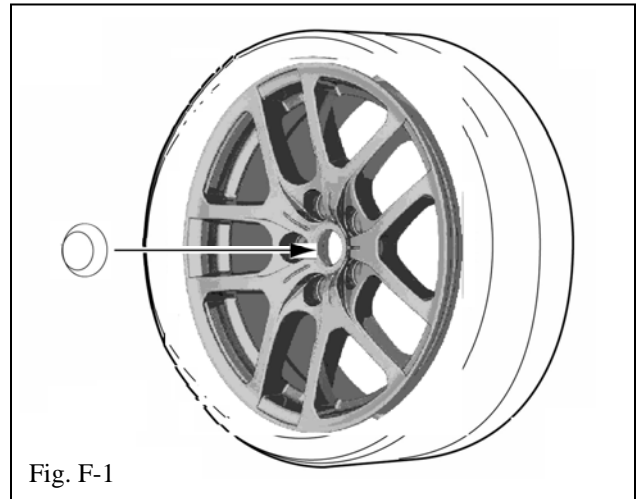

Fig. F-1

G. Tire Pressure Labels

1. Clean the surface and a small area around the OE tire pressure label located on the driver's side B-pillar door jamb.
2. Affix the 17 inch tire pressure label (MDC P/N 00107-00701) directly over the OE tire pressure label. (Fig. G-1)

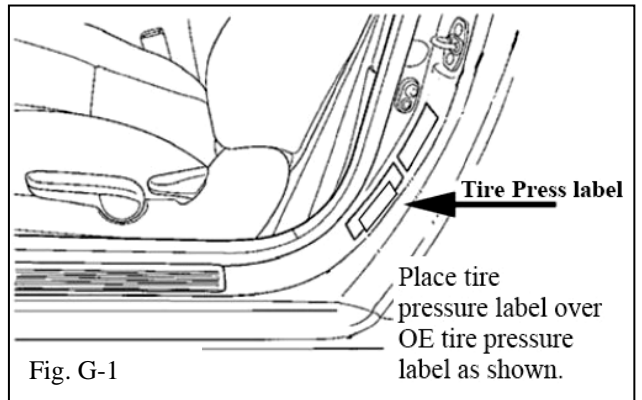
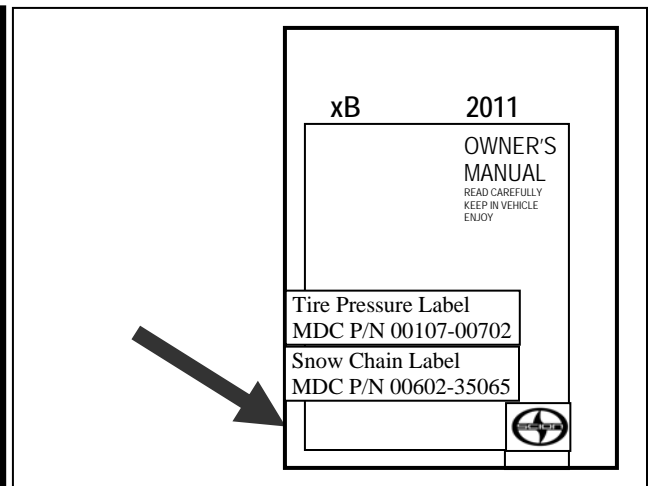

Fig. G-1

3. Install Owner's Manual Label (MDC P/N 00107-00702) and Snow Chain Label (MDC P/N 00602-35065) onto the lower left of the owner's manual above the SCION logo. (Fig. G-2)

NOTE: Be sure NOT to cover any existing text or information.





Section III – Functional Verifications

Check: _____

- Inspect Lug nuts
- Lug nut tightness
- Correct tire pressure
- B-pillar & owner's manual stickers are installed.

Look For: _____

Five lugnuts must be installed on each wheel.

Tighten to 76 lbf•ft (103 N•m) torque.

Verify that tire pressure is set to value listed on new B-pillar sticker \pm 2 PSI.

Confirm both are installed:

- B-pillar: MDC P/N 00107-00701

- Owner's Manual: MDC P/N 00107-00702